



Project: _____

Catalog#: _____

Notes: _____

Date: _____

Type: _____

LED UFO HIGH BAY LIGHT (140LPW)



APPLICATIONS

- WAREHOUSES
- FACTORY
- RETAIL
- SCHOOLS
- CHURCHES
- STORAGES
- AIRPORT HANGARS
- GYMNASIUMS
- HIGH CEILINGS
- GARAGES
- TASK LIGHTING
- OTHER LARGE AREAS



KEY FEATURES

CONSTRUCTION

LED UFO High Bay Luminaire body is die-cast Aluminum housing finished with Black corrosion-free powder coating. IP65 Rated for dry & water resistant for wet locations. 6' Cord built in with IP67 Connectors.

OPTICAL SYSTEM

Shatterproof Type I Optics come standard and projects light into a wide open space evenly. Fully sealed against dirt & bugs. UGR<25

CERTIFICATION

ETL/cETL and DLC Premium Listed, FCC compliant; with LM79 & LM80, IP65 Rated.

ELECTRICAL

Luminaire is available in 100W/150W/200W High lumen efficacy 140+lm/W, 0-10V Dimming Driver Universal 100-277VAC, 50/60Hz. Optional: EM Battery & Sensor IK10 Rated, 6-10KV Surge Voltage Protection Built-In

INSTALLATION

Easy hook installation or optional Yoke Mount. 0-10V Dimming Wires are Purple & Grey. Optional Sensor installs with a twist, no tools. Flicker free start. CCT: 5000K.

WARRANTY

Industry leading Five (5) year manufacturer warranty in the USA..

ORDERING

MODEL NUMBER(S)

MODEL NUMBER	POWER	LUMENS PER WATT	LUMENS	COLOR TEMPERATURE	CRI	LIFE HOURS
HG-HL-100WLD	100 Watts	140 LPW	14,192 LM	5000K	80+	50,000 HRS.
HG-HL-150WLD	150 Watts	140 LPW	21,633 LM	5000K	80+	50,000 HRS.
HG-HL-200WLD	200 Watts	140 LPW	28,987 LM	5000K	80+	50,000 HRS.

100W LED UFO HIGH BAY LIGHT

PERFORMANCE DATA



ACCESSORIES



EM Battery Backup



Motion Sensor

DIMENSIONS

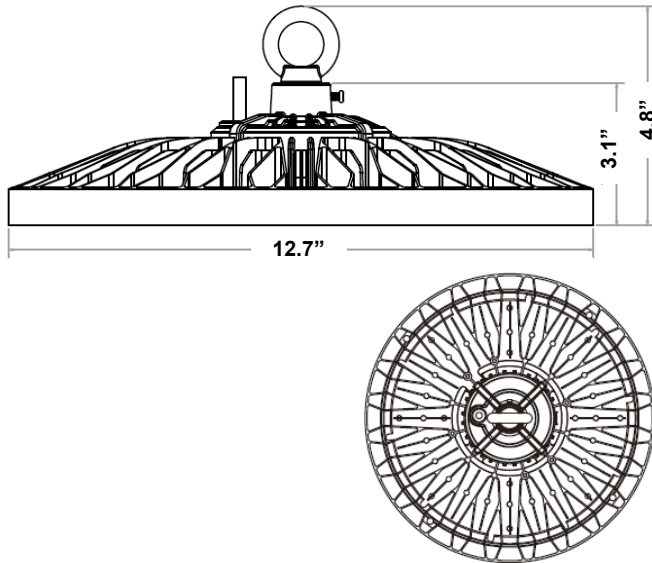

MODEL TECHNICAL SUMMARY

HG-HL-100WLD	
INPUT WATTS	100 Watts
INPUT VOLTAGE	AC 120-277V
POWER FREQUENCY	50 / 60 HZ
EFFICACY	140 lm/W
LED CHIPS	SMD 3030
LED DRIVER	CONSTANT POWER
DELIVERED LUMENS	14,192 LM
COLOR TEMPERATURE	5000K
CRI	80+
WORKING TEMPERATURE	-30°C - +54°C
STORAGE TEMPERATURE	-30°C - +60°C
IP RATING	IP65 Rated
CERTIFICATION	ETL CE FCC DLC PREMIUM LISTED
WARRANTY TIME	5 Years
OPTIONAL ACCESSORY	90 Min. EM Backup / Sensor
DIMMABLE	0-10V Dimmable
BEAM ANGLE	110°
THD	<10%
POWER FACTOR	>0.90
L70 (HOURS)	50,000
DIMENSIONS (L*W*H) INCHES	12.7" * 12.7" * 4.8"

PHOTOMETRICS

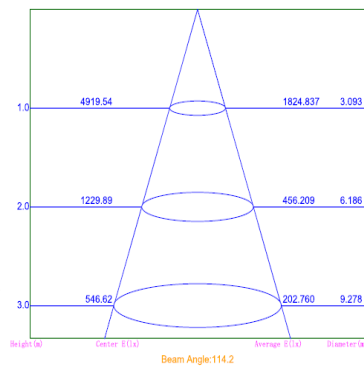
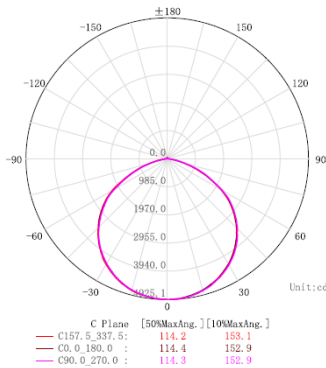

DLC LISTING



HG-HL-100WLD-50K8023-S1[BR,WH,BK][blank,M]

Manufacturer: UFO LIGHTING INC
 Brand: HG

PRODUCT OVERVIEW	
Classification	Premium
Primary Use	High-Bay Luminaires for Commercial and Industrial Buildings
Reported Input Wattage	98.63 W
Reported Light Output	14192.9 lm
Reported CCT	5000 K
Reported CRI (Ra)	83

PRODUCT INFORMATION	
Product ID	PBEEHL
Manufacturer	UFO LIGHTING INC
Brand	HG
Model Number	HG-HL-100WLD-50K8023-S1[BR,WH,BK][blank,M]
Parent	No
Classification	Premium
DLC Family Code	XXXELL
Input Power Type	AC

150W LED UFO HIGH BAY LIGHT

PERFORMANCE DATA



ACCESSORIES



EM Battery Backup



Motion Sensor

DIMENSIONS

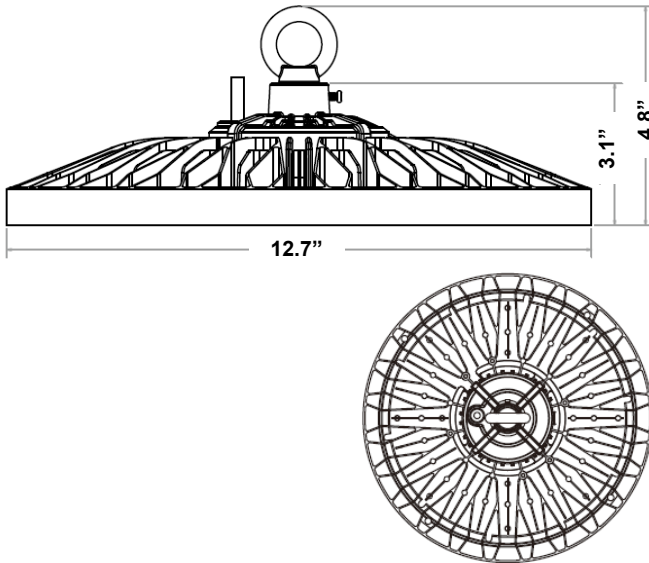

MODEL TECHNICAL SUMMARY

HG-HL-150WLD

INPUT WATTS	150 Watts
INPUT VOLTAGE	AC 120-277V
POWER FREQUENCY	50 / 60 HZ
EFFICACY	140 lm/W
LED CHIPS	SMD 3030
LED DRIVER	CONSTANT POWER
DELIVERED LUMENS	21,633 LM
COLOR TEMPERATURE	5000K
CRI	80+
WORKING TEMPERATURE	-30°C - +54°C
STORAGE TEMPERATURE	-30°C - +60°C
IP RATING	IP65 Rated
CERTIFICATION	ETL CE FCC DLC PREMIUM LISTED
WARRANTY TIME	5 Years
OPTIONAL ACCESSORY	90 Min. EM Backup / Sensor
DIMMABLE	0-10V Dimmable
BEAM ANGLE	110°
THD	<10%
POWER FACTOR	>0.90
L70 (HOURS)	50,000
DIMENSIONS (L*W*H) INCHES	12.7" * 12.7" * 4.8"

PHOTOMETRICS

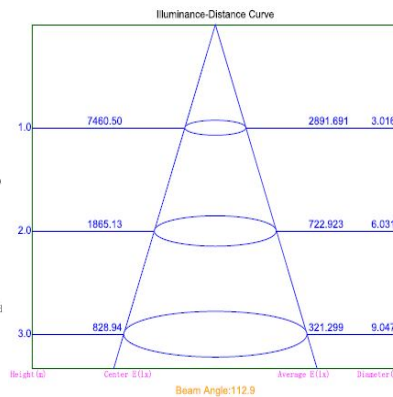
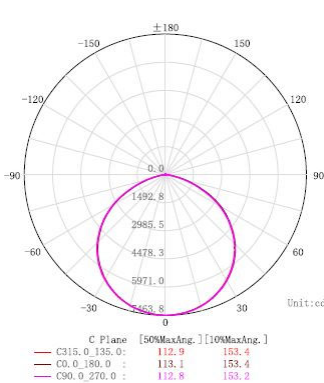

DLC LISTING



HG-HL-150WLD-50K8023-S1[BR,WH,BK][blank,M]
 Manufacturer: UFO LIGHTING INC
 Brand: HG

PRODUCT OVERVIEW

Classification	Premium
Primary Use	High-Bay Luminaires for Commercial and Industrial Buildings
Reported Input Wattage	148.91 W
Reported Light Output	21633.6 lm
Reported CCT	5000 K
Reported CRI (Ra)	83

PRODUCT INFORMATION

Qualified Product List	Solid State Lighting
Technical Requirements Version	S.1
Product ID	POBCLKU
Manufacturer	UFO LIGHTING INC
Brand	HG
Model Number	HG-HL-150WLD-50K8023-S1[BR,WH,BK][blank,M]
Parent	No

200W LED UFO HIGH BAY LIGHT

PERFORMANCE DATA



ACCESSORIES



EM Battery Backup



Motion Sensor

DIMENSIONS

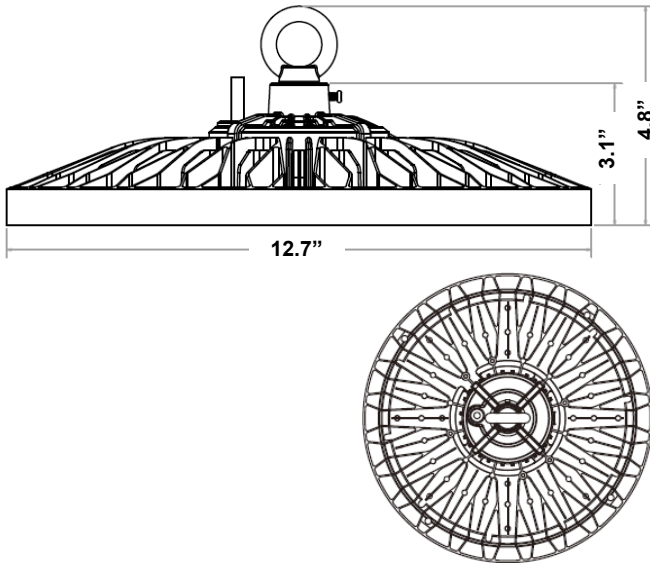

PHOTOMETRICS

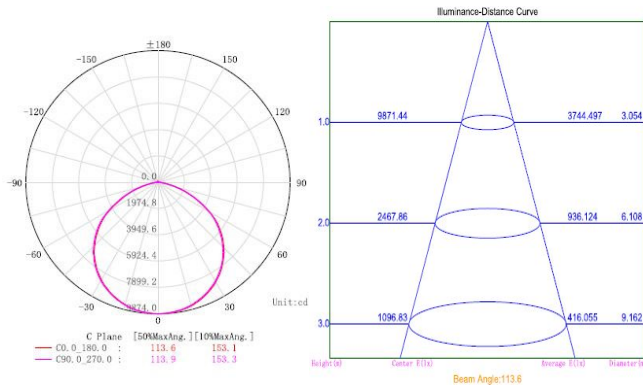

MODEL TECHNICAL SUMMARY

HG-HL-200WLD

INPUT WATTS	200 Watts
INPUT VOLTAGE	AC 120-277V
POWER FREQUENCY	50 / 60 HZ
EFFICACY	140 lm/W
LED CHIPS	SMD 3030
LED DRIVER	CONSTANT POWER
DELIVERED LUMENS	28,987 LM
COLOR TEMPERATURE	5000K
CRI	80+
WORKING TEMPERATURE	-30°C - +54°C
STORAGE TEMPERATURE	-30°C - +60°C
IP RATING	IP65 Rated
CERTIFICATION	ETL CE FCC DLC PREMIUM LISTED
WARRANTY TIME	5 Years
OPTIONAL ACCESSORY	90 Min. EM Backup / Sensor
DIMMABLE	0-10V Dimmable
BEAM ANGLE	110°
THD	<10%
POWER FACTOR	>0.90
L70 (HOURS)	50,000
DIMENSIONS (L*W*H) INCHES	12.7" * 12.7" * 4.8"

DLC LISTING



HG-HL-200WLD-50K8023-S1[BR,WH,BK][blank,M]

Manufacturer: UFO LIGHTING INC
Brand: HG

PRODUCT OVERVIEW

Classification	Premium
Primary Use	High-Bay Luminaires for Commercial and Industrial Buildings
Reported Input Wattage	200.12 W
Reported Light Output	28987.4 lm
Reported CCT	5000 K
Reported CRI (Ra)	83

PRODUCT INFORMATION

Product ID	PI4V205V
Manufacturer	UFO LIGHTING INC
Brand	HG
Model Number	HG-HL-200WLD-50K8023-S1[BR,WH,BK][blank,M]
Parent	No
Classification	Premium
DLC Family Code	XXXCELL
Input Power Type	AC