



Project:	
Catalog#:	
Notes:	Date:
Type:	

LED GARAGE CANOPY LIGHT



APPLICATIONS

- EXTERIOR WALLS
- AIRPORTS
- FACTORY
- OFFICE BUILDINGS
- LANDSCAPING
- FAST FOOD RESTAURANTS
- SCHOOLS
- CITY HALL
- CHURCHES
- HISTORICAL AREAS
- HOTELS
- OTHER OUTDOOR APPLICATIONS



KEY FEATURES

CONSTRUCTION

Slim Garage Canopy Luminaire body is die-cast Aluminum housing with Bronze corrosion-free powder coating finish. Fin Design with grooves provide excellent heat dissipation. High Temp Silicone Gaskets for wet area.

OPTICAL SYSTEM

Shatterproof Type I Optics come standard and projects light into a wide open space evenly. Fully sealed against dirt & bugs. SMD3030 LED chip sets the perfect light.

CERTIFICATION

ETL/cETL Listed, FCC compliant; with LM79 & LM80, IP65 Rated.

ELECTRICAL

Luminaire is available in 45W & 70W
 High lumen efficacy 130lm/W, Non-Dimming, Isolated Driver
 Universal 100-277VAC, 50/60Hz.
 45W=5,850 Lumens—70W=9,100, Lumens

INSTALLATION

Easy installation on standard junction box or surface mount. 4 total 3/4" threaded knockouts for easy access to conduit & controls. Flicker free. CCT: 5000K. Mounting Height 8'-15'

WARRANTY

Industry leading Five (5) year manufacturer warranty in the USA.

ORDERING

MODEL NUMBER(S)

MODEL NUMBER	POWER	LUMENS PER WATT	LUMENS	COLOR TEMPERATURE	CRI	LIFE HOURS
CP01-5001	45 Watts	130 LPW	5,850 LM	5000K	80+	50,000 HRS
CP03-5001	70 Watts	130 LPW	9,100 LM	5000K	80+	50,000 HRS

45W LED PARKING GARAGE CANOPY LIGHT

PERFORMANCE DATA



ACCESSORIES



EM Battery Backup



Bi-Level Occupancy Sensor

DIMENSIONS

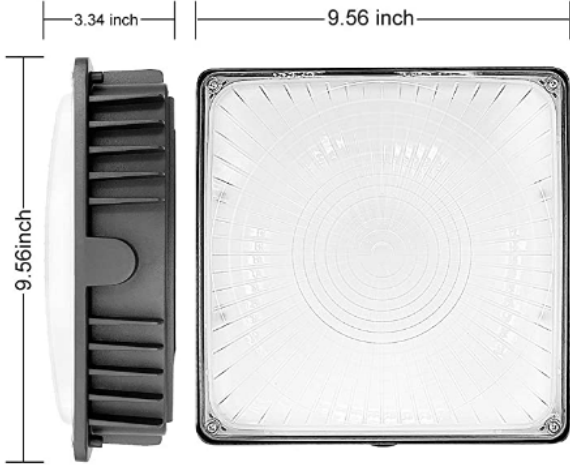

MODEL TECHNICAL SUMMARY

CP01-5001	
INPUT WATTS	45 Watts
INPUT VOLTAGE	AC 120-277V
POWER FREQUENCY	50 / 60 HZ
EFFICACY	130 lm/W
LED CHIPS	SMD3030
LED DRIVER	CONSTANT POWER
DELIVERED LUMENS	5,374 LM
COLOR TEMPERATURE	5000K
CRI	80+
WORKING TEMPERATURE	-40°C - +40°C
STORAGE TEMPERATURE	-40°C - +70°C
IP RATING	IP65
CERTIFICATION	ETL CE FCC RoHS
WARRANTY TIME	5 Years
OPTIONAL ACCESSORY	Photocell / Occupancy Sensor / EM Battery
DIMMABLE	Non-Dimmable
BEAM ANGLE	155°
THD	<20%
POWER FACTOR	>0.90
L70 (HOURS)	50,000
DIMENSIONS (L*W*H) INCHES	9.56" * 9.56" * 3.34"



70W LED PARKING GARAGE CANOPY LIGHT

PERFORMANCE DATA



ACCESSORIES



EM Battery Backup



Bi-Level Occupancy Sensor

DIMENSIONS

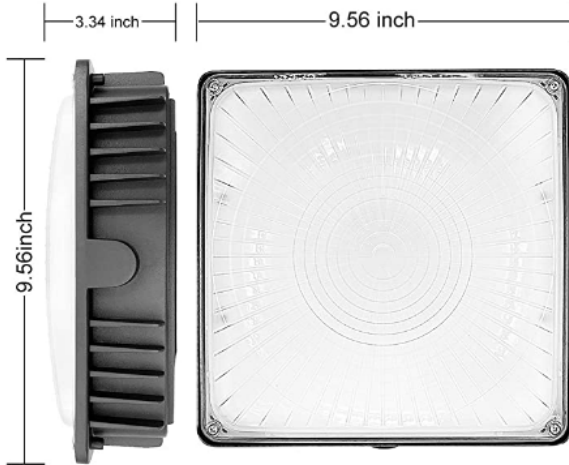

MODEL TECHNICAL SUMMARY

CP03-5001	
INPUT WATTS	70 Watts
INPUT VOLTAGE	AC 120-277V
POWER FREQUENCY	50 / 60 HZ
EFFICACY	130 lm/W
LED CHIPS	SMD3030
LED DRIVER	CONSTANT POWER
DELIVERED LUMENS	9,100 LM
COLOR TEMPERATURE	5000K
CRI	80+
WORKING TEMPERATURE	-40°C - +40°C
STORAGE TEMPERATURE	-40°C - +70°C
IP RATING	IP65
CERTIFICATION	ETL CE FCC RoHS
WARRANTY TIME	5 Years
OPTIONAL ACCESSORY	Photocell / Occupancy Sensor / EM Battery
DIMMABLE	Non-Dimmable
BEAM ANGLE	155°
THD	<20%
POWER FACTOR	>0.90
L70 (HOURS)	50,000
DIMENSIONS (L*W*H) INCHES	9.56" * 9.56" * 3.34"

